



est. 1946

Front End Components



GT2 Stainless Steel Front Batwings: These beautiful investment cast "bushing style" S/S Batwings offer some of the nicest styling in the business. Not only good looking, they feature built-in lower shock mounts, come in either a highly polished or plain finish and ready to install.

- (A) #001-61001 GT2 polished batwings: \$289.00 pr.
- (B) #001-61002 GT2 plain batwings: \$239.00 pr.

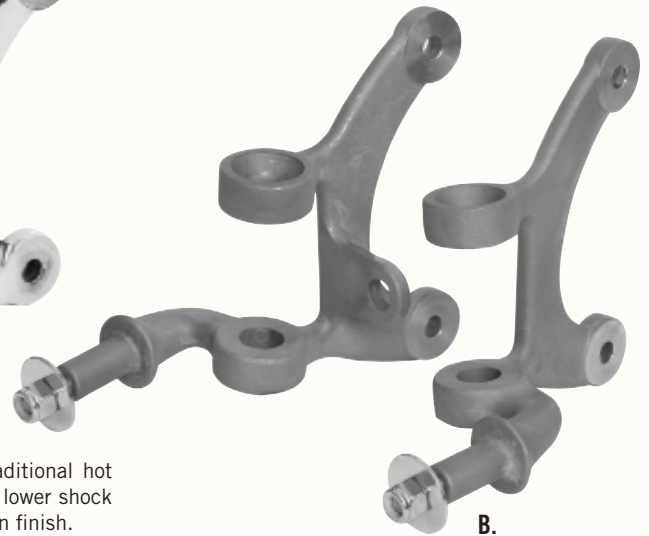
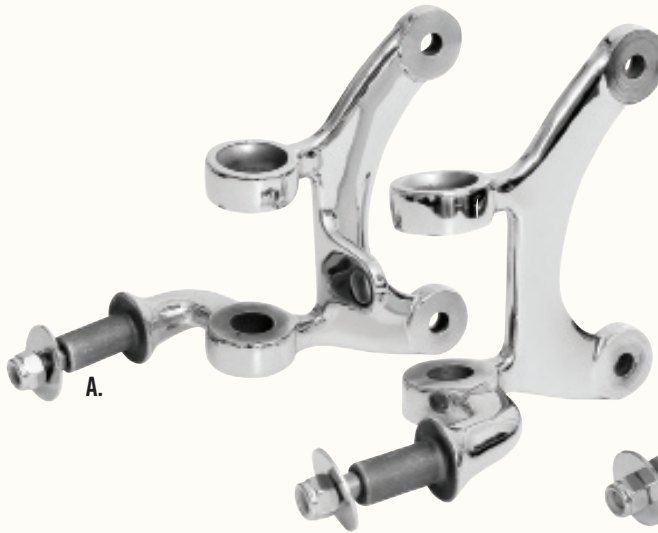

SO-CAL New Traditionalist S/S Batwings: Here's the product that revolutionized traditional hot rod front ends. These batwings are investment cast S/S and feature not only built-in lower shock mounts but a panhard bar mount as well. They are offered in either a polished or plain finish.

- (A) #001-60805 Polished SO-CAL batwings: \$249.99 pr.
- (B) #001-60806 Plain SO-CAL batwings: \$199.99 pr.

Front Radius Rod Frame Tabs: These CNC machined weld-on tabs feature a machined outside radius and integral boss. (A) has a 7° tapered hole to fit early Ford tie rod ends on 7/8" centers, (B) has a 1/2" hole for urethane adjusters on 7/8" centers, (C) has a 7° tapered hole to fit early Ford tie rod ends on 1 7/8" centers, (D) has a 1/2" hole for urethane adjusters on 1 7/8" centers.

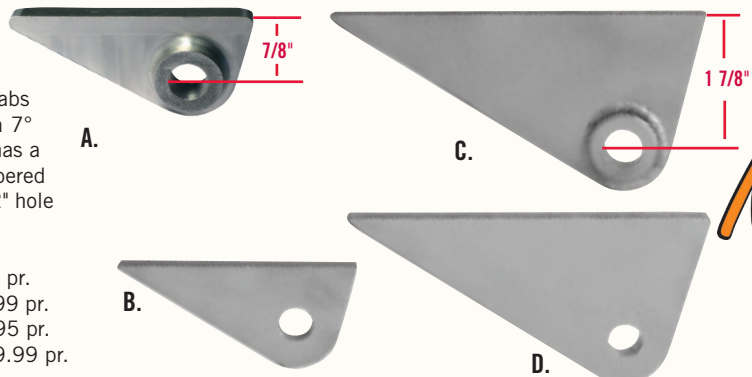

New

- (A) #001-62152 Frame tab, 7° hole with 7/8" centers: \$29.99 pr.
- (B) #001-62153 Frame tab, 1/2" hole with 7/8" centers: \$14.99 pr.
- (C) #001-62158 Frame tab, 7° hole with 1 7/8" centers: \$19.95 pr.
- (D) #001-62151 Frame tab, 1/2" hole with 1 7/8" centers: \$19.99 pr.