

Bump Steering

A frame mounted on transverse leaf springs located by spring shackles is free to move from side to side which, in turn, causes the drag link to move. The movement of the drag link causes the spindles to move and thus the wheels to turn without input from the steering wheel causing bump steer. Bump steer is also a problem during hard, fast cornering when the rear end wants to break loose. For example, during a turn, the steering wheel is turned and the drag link moves. The centrifugal force caused by the turn causes the weight of the car to shift and rock on the shackles. The steering gear and drag link, being connected to the frame, also move. This additional drag link movement then causes the spindles to turn more than the desired input.

To eliminate this undesirable side-to-side motion, a Panhard bar is used to control lateral movement between the frame and axle. Due to its importance, SO-CAL has incorporated the Panhard bar axle bracket into the batwings. GT2 Stainless offers a direct bolt-on bracket for its batwings as well. To further enhance steering feel, we strongly recommend the use of a steering stabilizer to improve smoothness and eliminate the possibility of shimmy.

Typical cross steering front end without Panhard bar.

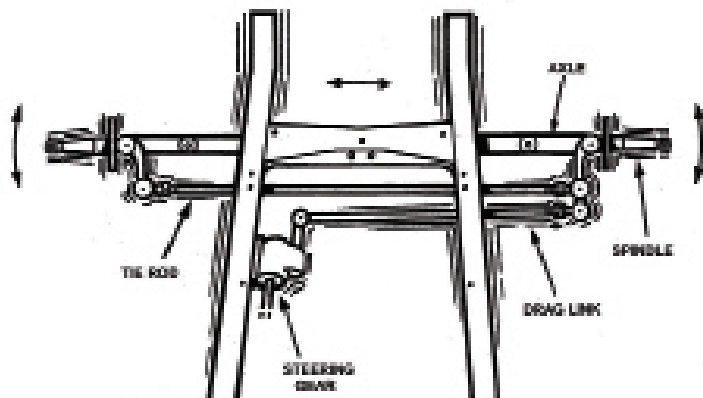

Typical cross steering front end with Panhard bar.

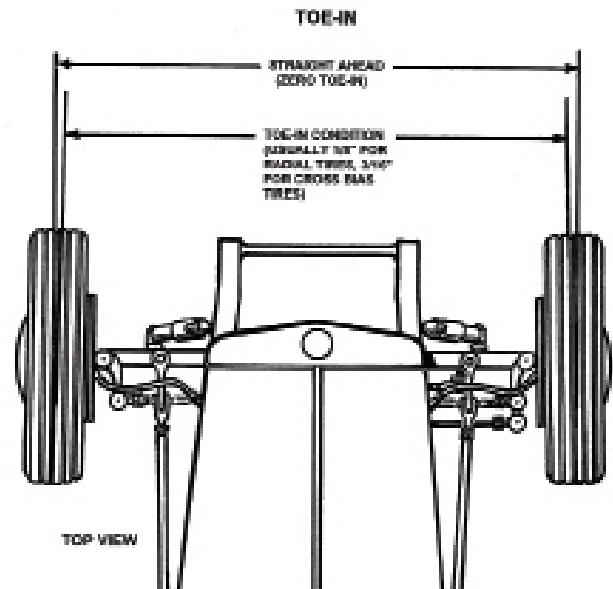
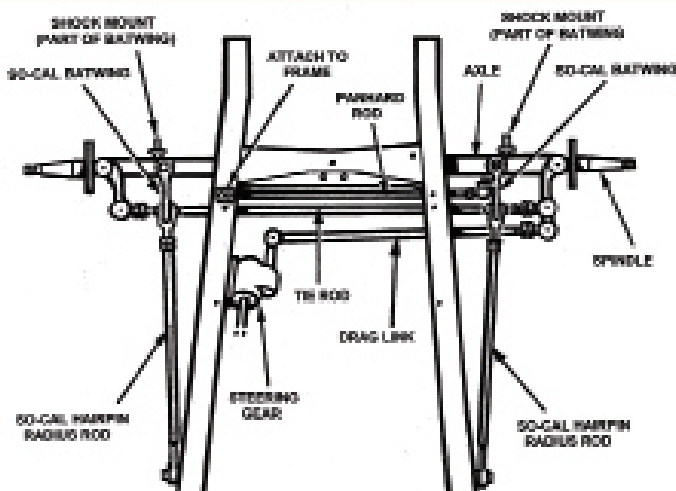

Vega Cross Steering

Cross steering is not a recent innovation. In fact, Ford used it between 1909 and 1927 and again from '35 thru '48. We use a Vega-style aftermarket steering box today because of its compact size, clean appearance and uncompromising recirculating ball worm gear design.

CASTER

Caster is the backward or forward tilt of the kingpin measured in degrees from true vertical. The aft tilt of the kingpin is called positive caster. The angle of caster effects the steering, e.g., positive caster causes the front wheels to run straight and influences the return to center of the steering box. Negative caster causes the steering to be "touchy" and harder to control. In our experience, a hot rod with I-beam or tube axle needs between 5 and 9 degrees of positive caster and is set by adjusting the radius rods.

CAMBER

Camber is the inward or outward tilt of the wheels, measured in degrees from true vertical, when viewed from the front. Positive camber is when the wheels lean out at the top, negative when the wheels lean in. Excessive camber will cause premature and uneven tire wear. In most hot rods, the camber should be between zero and 1/2 degree positive and in most cases the camber is engineered into the axle at the angle at which the kingpin hole is machined into the kingpin boss. If your camber is incorrect, a really good "old-school" front end shop should be able to help.

TOE-IN

Toe-in, toe-out is the angle at which the wheels point when viewed from the top. Toe-in is when the wheels point slightly toward each other at the front, toe-out is when they point away from each other. In our experience, hot rods with radial tires should be set with 1/8-inch toe-in. Hot rods with bias-ply tires should be set with 3/16-inch toe-in. Adjustment is best set at a front end shop.